

Simple.Sensible.Smart

TELN 1402
Gateway Interface Module
Version 1.0

Users Manual
July 1998

Techlon Instruments, Inc.
P.O. Box 127
Topton, PA 19562
(610)682-9764 (610)682-9765 FAX
E-mail: techlon@enter.net

CONTENTS

TELN 1402 Gateway Interface Module

Introduction:	3
Contacts and Service representatives:	3
Specifications	4
Dimensions	4
Transceiver Support	4
DC Power Supply Information	4
Equipment.....	5
Operation	5
Board Layout	6
Installation.....	8
Wiring Diagram	9
Communications Cable RJ45 Installation.....	10
Network.....	11
Network Variables	13
Appendix A: Input Network Variable	14
Appendix B: Output Network Variable	15
Appendix C: Master SNVT List:	16
Appendix D: Service of TELN 1402.....	16
Appendix E: Network Maintenance Neuron Error Codes	17
Appendix F: Trouble Shooting.....	18

TELN 1402

LonWorks™ Gateway Interface Module

INTRODUCTION

Techlon's Gateway Interface module (TELN 1402) consisting of (TELN 1070b Gateway CPU, TELN 1266 3Amp Gateway Power Supply, TELN 1263 Gateway Backplane, and a Single Board Computer). The TELN 1402 is a Lonworks network interface with single board computer intended primary for video display and data analysis. The single board computer can be fitted with the following CPUs V40, 386 and 486. The TELN 1402 has an independent power supply board that is designed to power the single board computer, TELN 1070 Gateway CPU and an externally interfaced floppy drive. The TELN 1402 module is supported with a reset switch, service switch, service LED, power supply LEDs, internal self test and optional 2 key input analog switch group. The video display is designed for use with VGA.

A number of connector schemes are supported:

Communications : dual RJ45 phone or .2" center to center terminal locks.

Video Out : HD 15 PIN D- SUB Plug.

Power input/output: .2" center to center terminal block, .25" Fastcon spade connector, or

AMP INNERGY series PC mount connectors.

Download interface: .100" x .100" Plug Connectors.

Switch Inputs: 10 PIN Protected Headers

The board is mounted on grounding standoffs. There is also a grounding connection to the board, and a chassis ground stud on the outside of the module enclosure.

Contacts and Service representatives:

Susan Gabel - President

Warranty Information.

Brian Gabel - VP/Director of Engineering

Hardware Problems.

Kevin Miller - Senior Software Engineer

Software Problems.

Call 1-(610)682-9764 and ask to be connected to your party.

Specifications.

- 2K Ram

- 512 Byte EEPROM on Neuron Chip for (Network Information).
- 2K EPROM for (application code).
- 1M Flash for SBC (Single Board computer) application code.
- 640K DRAM on SBC.
- 20MHz on SBC CPU
- Video support S-VGA
- Voltage: Operating: 8V–18V DC; Max.: 7.5V–33V DC
- Expanded voltage available.
- Operating Temperature: -40° C to +85° C.
- Storage Temperature: -60° C to +100° C.

Dimensions

Board Dimensions:

TELN 1070 4" w x $3\frac{7}{8}$ " h x $\frac{3}{4}$ " deep.

TELN 1266 4" w x $4\frac{7}{8}$ " h x 1" deep.

TELN 1263 4" w x $2\frac{1}{2}$ " h x 1" deep.

SBC 4" w x $3\frac{7}{8}$ " h x $\frac{3}{4}$ " deep.

NEMA 1 packaging is supported by a 4" w x $4\frac{7}{8}$ " h x 5" deep aluminum chassis, with two irradiated aluminum side plates with slots for mounting screws and an external 6-32 stud for chassis grounding.

Other package and connector configurations available by request.

Transceiver Support

TELN 1402 Provides support for the following types of transceivers:

- 1.2 M TPT
- 78K TPT
- RS-485
- 78K Free Topology (FTT-10)
- Direct-Connect (up to 90 feet)

DC Power Supply Information

Module logic power is drawn from TELN 1266.

Module positive (+)power is supplied to the node through terminals T0 (marked +SUP. on the enclosure cover). **Note:** The Unit is also capable of supporting AC power input upon request. The power input terminals are T0 and T1 (marked +SUP and -SUP on the enclosure cover).

Equipment

Techlon Provides:

1 TELN 1402 Gateway Interface module mounted in a NEMA 1 packaging supported by a 4" w x 4 $\frac{7}{8}$ " h x 5" deep aluminum chassis, with two irradiated aluminum end plates that have slots for mounting screws and an external 6-32 stud for chassis grounding. (Customized mountings are available.).

Must be supplied by customer:

Power source: 12V DC, 1.5A source for logic.

Power cables.

Communication cables .

Operation

Safety Warning

HAZARD OF SEVERE ELECTRICAL SHOCK OR BURN.

Remove power to unit before opening the cover.

Replace fuses only with approved automotive types rated for the loads connected to this device.

When the unit is first powered up, Service LED will flash once quickly. After approximately 1 second the board will have completed self tests, and any changes to unit status will be indicated by the module's LED indicators:

LED	ON	OFF	Flash
Service (yellow) Indicates the state of the module	Application-less (off-line) and unconfigured	On-line and Neuron application and network parameters configured	With application (on-line) but unconfigured. Or, board information is being downloaded to the network

The Service switch is used to initiate a network management message identifying the module to the network. The Reset switch resets system logic and forces all outputs to their OFF state.

- The input network variables are used for controlling the TELN 1402's TELN 1070b.
- The output network variables are used for status from the TELN 1402's TELN 1070b.

The Network Variables can be found in the following appendices.

- Appendix A: has a list of Input Network Variables.
- Appendix B: has a list of Output Network Variables.

Board Layout

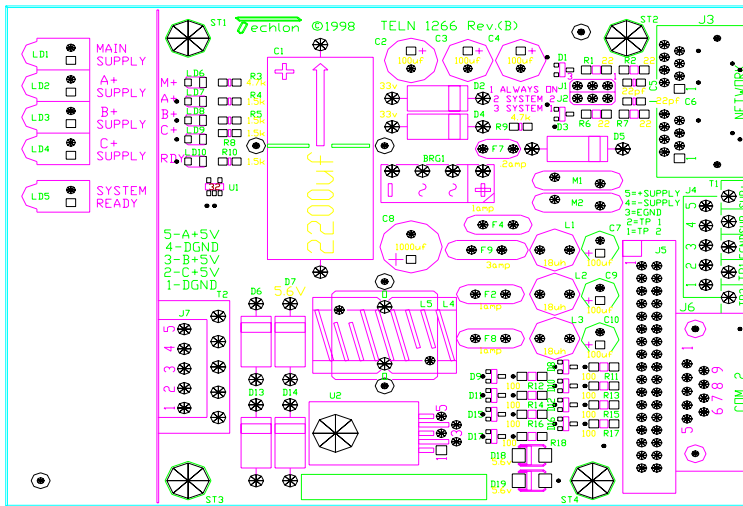
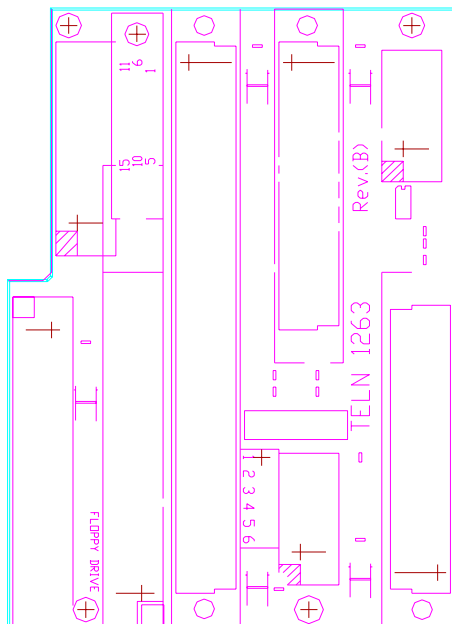

Figure 1.0 TELN 1266 Power Supply Board



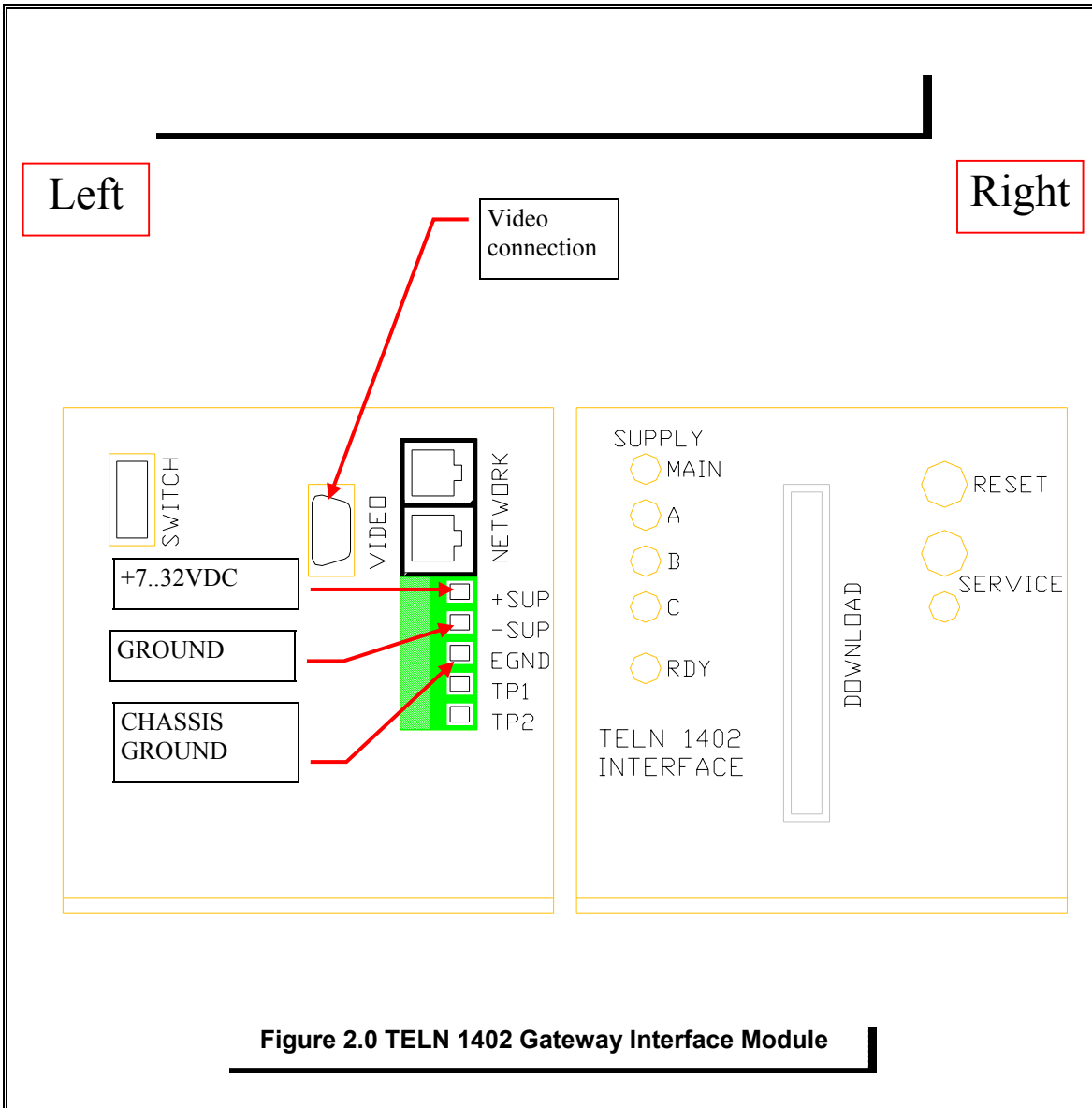

Figure 2.0 TELN 1402 Gateway Interface Module

The TELN 1402 may be connected to a floppy drive, though the "DOWNLOAD" connector, the TELN 1402 can also be connected to a monitor through the connector called "VIDEO". The power input for the module is labeled "+SUP", "-SUP" and "EGND". On the same connector we have "TP1" twisted pair 1 network connection and "TP2" twisted pair 2 network connection. The RJ45 connector is a Network connection as labeled "NETWORK". The MAXIMUM voltage must not exceed 24V. fused at no less than 1.5A.

To wire the TELN 1402 Gateway Interface Module, Refer to figure 2.0 for connector locations. Connect wires into connectors as needed following location and descriptions from figure 2.0.

TELN 1402 Wiring Diagram

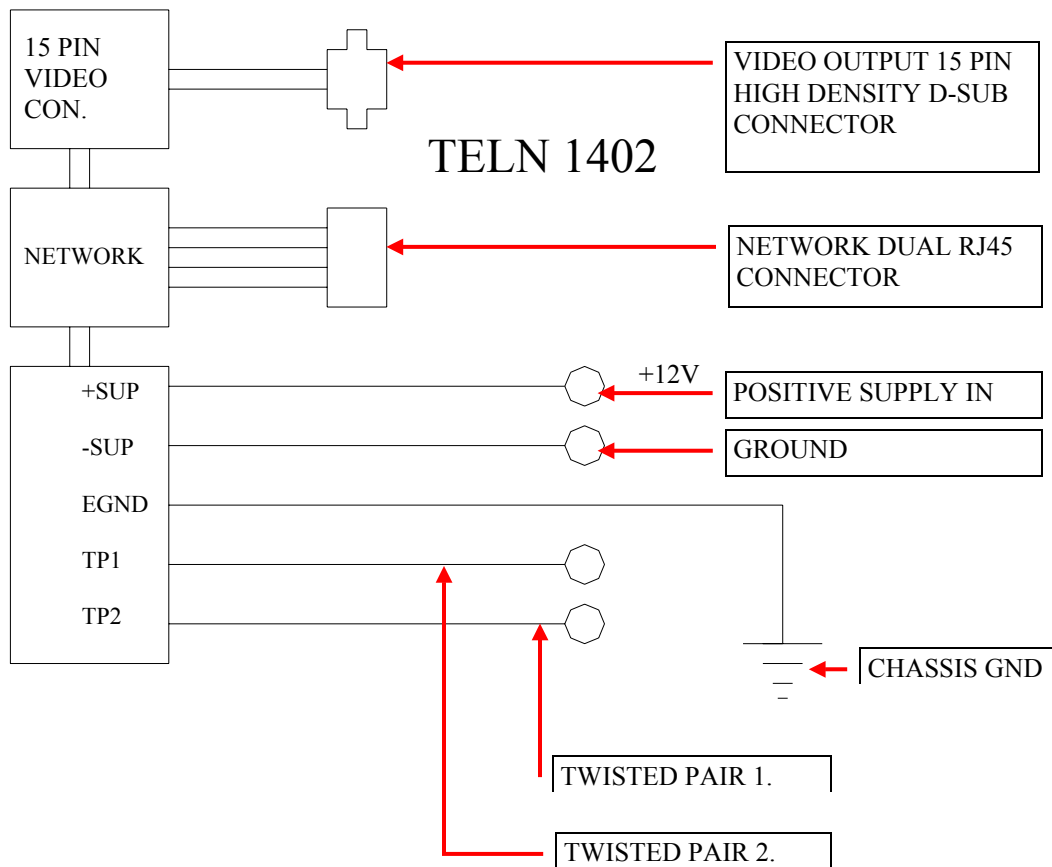

Figure 3.0 TELN 1402 Wiring Diagram

RJ45 Communication Wire Schematic

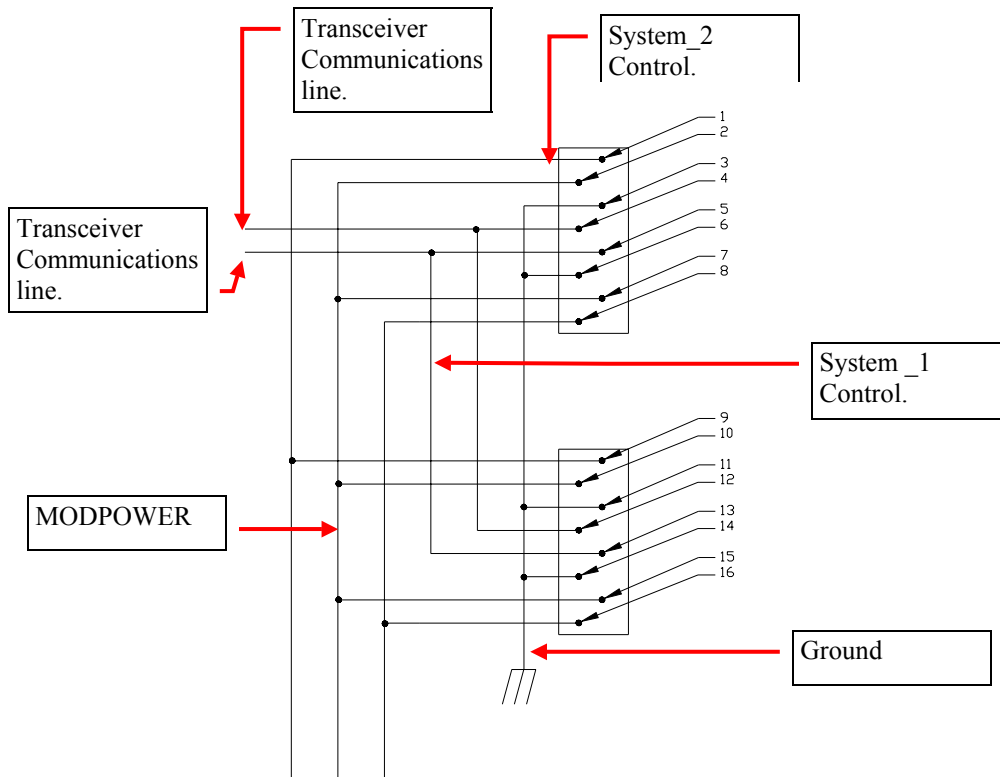

Figure 4.0 RJ45 Com. Connectors

- MODPOWER- Secondary Power supply.[Pins 2,7,10,15]
- System_1 Control.- Control for alternate power supply of System_1.[Pins 16,8]
- System_2 Control.- Control for alternate power supply of System_2. [Pins 9,1]
- Ground-System Ground [Pins 11,5,3,7]
- Transceiver Communications line(1) -Twisted pair [Pins for TP1 are 12,4]
- Transceiver Communications line(2) -Twisted pair [Pins for TP2 are 13,5]

Network

Though the TELN 1402 may be used as a standalone device, connecting it as a member of an integrated peer to peer network, it will permit all the board's functions to be used and configured to their maximum benefit. This allows you to read status, check error tables and rebind control devices.

To install the device onto a network:

Module Installation Into The Network

1. Check to make sure that the module's transceiver type is supported by the general network arrangement (i.e., TP/XF-78). If not, a router module may be required.
2. Connect the ground wire to the lug on the board or the stud on the enclosure.
3. Connect the Power and Output wires as depicted in figure. 2.0 . This will power the board and connect the loads to the Outputs.
4. Connect the telephone type cable [RJ45] from the Network.
5. With the Network Management tool attached to the Network, INSTALL the node. Click on INSTALL; then, when prompted press the service button [next to the yellow LED] on the TELN 1402 board. At this time the network will be downloading application information to the node and the Yellow service LED will blink for the duration indicating the download is taking place. When the download is completed the LED will turn off. When the process is completed, click the WINK button. This will cause a small LED on the TELN 1402 board to blink for 10 seconds. Do a TEST of the TELN 1402 node (See table 1.0 for more information).
6. This board can now be used for its intended Network application.

Table 1.0 Test Results
Node TELN 1402 Test Results

Name:	Result:	Explanation:
General Information		
Neuron Chip Model:	The model number.	This returns the model number of the neuron chip used on the TELN 1402.
Software Version:	The firmware version number.	This gives a version number for the Neuron firmware code.
Last Error logged:	This gives an Error Condition Code found in Appendix F:	The last error that occurred.
Last Reset Caused:	Either a Network or Hardware reset. A. Power Up. B. Watchdog Time-out. C. External. D. Software.	The reasons that the node reset.
Bypass:	Either: Yes or NO	This refers to the nodes ability to repetitively pass on network messages.
State:	Status of Node. A: On-line B: Off-line C: Unconfigured. D: Applicationless.	The states are defined as. A: On-line means all Normal and activated. B: Off-line means all Normal but not activated. C: Unconfigured means all Normal but configuration variables not set. D. Applicationless could be either a normal or abnormal condition. This means that there is no Application code for the node or the application code is corrupted.
Lost messages:		
Network Layer:	The result will be a number of errors.	The node received a message that it was forced to discard before it was acted upon. The Network buffer was full.
Application layer:	The result will be a number of errors.	The node received a message but was forced to discard before it was acted upon. If the error occurs, the reason could be that there is either inadequate Application buffer space or the node is too busy.
Communications Problem:		
Transmission Errors	The result will be a number of errors.	These errors are due to a bad communications cable connection.
Receive trans. full error:	The result will be a number of errors.	The receive message buffer is full. All messages cannot be received and are consequently lost.
Transaction Time-outs:	The result will be a number of errors.	The time limit set (time needed for a message to be sent and received by the node) has expired.

Network Variables

Input variables are for the following (see Appendix A for functional Input Network Variables and Appendix C for configuration Input Network Variables):

- Analog reading inputs
- Error clear input
- Frequency input
- Page turning input
- Module Status readings
- Time and Date input readings

Output variables are for the following (see Appendix B for Output Network Variables):

- Status of module
- Error log for module

Appendix A: Input Network Variables

The module uses the following input network variables. The network variables are ordered alphabetically by variable name, i.e., *NI_name*.

Input Network Variables	Variable Description and Content
NI_analog[] Type: Count, Incremental SNVT_count_inc	This is an input for Analog readings. There are 28 analog inputs from NI_analog[0] to NI_analog[27]. The analog values are integers. Tenths are assumed.
NI_error_clear Type: Count, Event SNVT_COUNT	Clears the stored error list. Any non-zero value will clear all entries in the error list, including the new error flag (first byte of string).
NI_freq Type: Frequency SNVT_freq_hz	Reads in a frequency to a precision of (0.1Hz).
NI_page Type: Level, Continuous SNVT_lev_cont	Used to input a page toggling. Either an On/Off condition.
NI_status[] Type: Level, Continuous SNVT_lev_cont	Reads in status from various modules. There are 18 status inputs from NI_status[0] to NI_status[17]. NI_status[17] contains the settings for the number of seconds to wait between screen updates. They are incremented at 0.5sec. The MAX time is 5.0sec. the DEFAULT is 2.5sec.
NI_time Type: Time Stamp SNVT_time_stamp	Reads in the Time and Date of a clock input. The time is (Hours, Minuets, Seconds) and the Date is (Year, Mouth, Day).

Appendix B: Output Network Variables

The module uses the following output network variables they are ordered alphabetically by variable name, i.e., NO_ *name*.

Output Network Variables	Subdivisions	Variable Description and Content
NO_error Type: Int'l char set, SNVT_STR_INT		The most recent 15 errors. Offset 0 contains the newest and offset 14 contains the oldest. As an error occurs, the oldest error is dropped, all the rest move down one offset, and the new error is loaded in offset 0. The error values are bit mapped. See Appendix D.
	wide_char[0]	Most recent errors.
	" "	Errors {1} though {13}.
	wide_char[14]	Oldest error.
NO_status Type: Level Continuous, SNVT_LEV_CON		Indicates the board status. On-board self test. The node's status. this indicates the state of the node. Module Status States. 0.0 = Off - Board not energized. 0.5 = Green - Board is energized and no errors indicated. 1.0 = Red - Any supply voltage error, any high voltage or current error. 1.5 = Yellow - An a/d error.

Appendix C: Master SNVT List

The following is a list of SNVT types used with TELN 1402. SNVT types can be bound only with like SNVT types.

Name	Measurement	Range (Resolution)
SNVT_CONT_INC	COUNT	-32,768..32,767 COUNT (1 COUNT)
SNVT_COUNT	COUNT, EVENT	0..65,536 COUNTS
SNVT_FREQ_HZ	FREQUENCY	0..6553.5Hz (0.1)Hz
SNVT_LEV_CONT	LEVEL, CONTINUOUS	0..100% (0.5%)
SNVT_STR_INT	INT'L CHAR SET. CHAR SET CODE. 16 BIT CHARS. TERMINATOR.	14 WIDE CHARTERS. 0..255 14 CHAR. 0x0000.
SNVT_TIME_STAMP	TIME STAMP	(YYMMDD) (HH:MM:SS)

Appendix D: Service of TELN 1402

To service the TELN 1402 a Service Unite is required. The Seville unit is a 3.5 Floppy drive with a port for a AT keyboard.

1. To format the flash on the SBC, insert disk labeled "1402 Flash Format Disk" and rest TELN 1402 unit wait for conformation completion. If the flash does not format please call for assistance.
2. To Load TELN 1402 software update. (This is the application software for the SBC in the TELN 1402 and not the Neuron application software.) Insert the disk labeled "1402 Update Disk" into service unit and reset the TELN 1402 unit. Conformation and instructions will be displayed on the video display once completed. ***NOTE*** If the flash has not been formatted the "1402 Update Disk" will not be able to be copied to the flash.

Appendix E: Network Maintenance Neuron Error Codes

no error	0
bad_event	129
nv_length_mismatch	130
nv_msg_too_short	131
eeeprom_write_fail	132
bad_address_type	133
preemption_mode_timeout	134
already_preempted	135
sync_nv_update_lost	136
invalid_resp_alloc	137
invalid_domain	138
read_past_end_of_msg	139
write_past_end_of_msg	140
invalid_addr_table_index	141
incomplete_msg	142
nv_update_on_outupt_nv	143
no_msg_avail	144
illegal_send	145
unknown_PDU	146
invalid_nv_index	147
divide_by_zero	148
invalid_appl_error	149
memory_alloc_failure	150
write_past_end_of_net_buffer	151
appl_cs_error	152
cnfg_cs_error	153
invalid_xcvr_reg_addr	154
xcvr_reg_timeout	155
write_past_end_of_appl_buffer	156
io_ready	157
self_test_failed	158
subnet_router	159
Authentication_mismatch	160
self_inst_semaphore_set	161
read_write_semaphore_set	162
appl_signature_bad	163
router_firmware_version_mismatch	164
Eeprom_Recovery_occurred	166
triac_clockedge_+-_not_supported	167
checksum_error_over_system	168
state_byte_semaphore	192-223

Appendix F: Trouble Shooting

Problem:	Suggested Solution:
Display dose not come up but network connection is established.	1. The video cable is not plugged in.
	4. The single board computer dose not work. Return TELN 1402 for repairs.
	2. The Flash on the TELN 1402's SBC needs to be reloaded See Appendix E: for service instructions.
Display comes up but the does not talk to the Network	SEE NEXT PROBLEM (Does not talk to Network).
Does not talk to Network.	1. Look to see if communication cables are connected. Connect unconnected cables.
	2. Check to see if board is powered. Power unpowered board.
	3.* Unconfigured. Load application.
	4. Compare communication cables to figure 3.0 if cables are not the same, redo according to schematic.
Board has Power but does not work.	An internal fuse may be blown. You may have an over voltage or too large of a current draw. Verify with a meter.
For all other problem please consult your warranty contract or call the service representatives as listed.	

* Note *

* Using a third party Network management tool to load your application to Configure the Neuron parameters.